

Proper installation of the anchor is vital to good work.

### HOW TO USE THE PBBA: HOLD DOWN ANCHOR

In locking down the Bar always check and note position of (1, Figure #5) which is a side view of clamp assembly. If anchor elevating screw is at proper height above top of block (approx. 2"), clamp and base will appear (Figure #5). Always check and make sure that rod (1, Figure #5) is not wedging against back of motor. Bridge (2, Figure #5) can be moved back slightly so that rod (1, Figure #5) does not contact motor.

Before an actual job is attempted the operator should practice with the Bar on an old junk block to make sure he understands thoroughly all details connected with the use of the Boring Bar and that the Bar bores to the diameter the tool has been set.

Side view of Cylinder Boring Bar Clamping Device

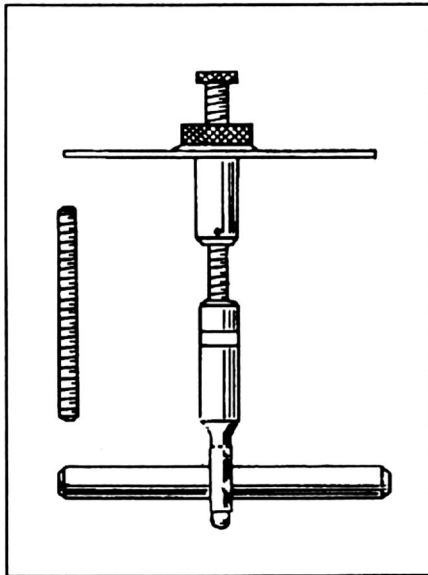

Figure 4

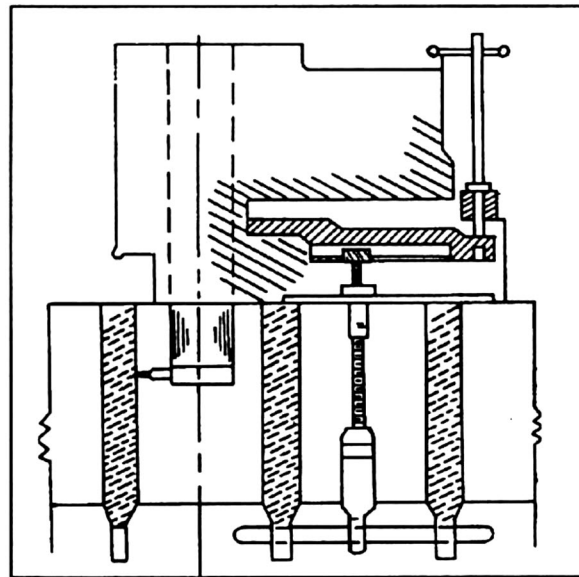

Figure 5